



Hornady[®]

Accurate. Deadly. Dependable.

Custom-Grade[™] Dies

Crimp/Seater Die



SET UP

Depending on the caliber of die set/alignment sleeve you are using, the Hornady Crimp/Seater Die will either "taper" or "roll" crimp your cases.

1. As with all dies, disassemble the Crimp/Seater Die and clean thoroughly.
2. Reassemble according to illustration, setting the distance between the Crimp Adjust Screw and the Crimp Adjust Lock Ring to approximately $\frac{1}{4}$ inch. When tightened properly, the Crimp Adjust Lock Ring should have firm tension on the O-ring against the Seater Die Body.

3. With a case in the shell holder, raise the press ram to the top of its stroke. Screw the assembled Crimp/Seater Die into the press until resistance is felt. This resistance is the case starting to crimp in the Alignment Sleeve.
4. Screw the Sure-Loc Lock Ring down against the press or Lock-N-Load® Bushing and lock into place by tightening the cap screw on the ring.
5. Loosen the Crimp Adjust Lock Ring while holding the Crimp Adjust Screw and then back the Crimp Adjust Screw off approximately $\frac{1}{2}$ turn. Retighten the Crimp Adjust Lock Ring while holding the Crimp Adjust Screw.

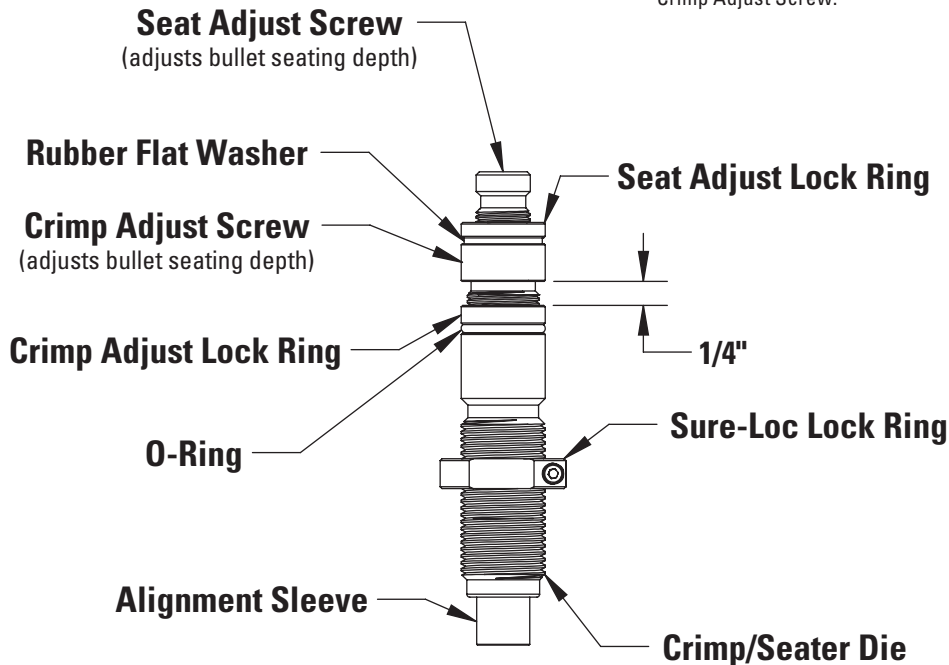

- 6.** Now we will set the bullet seating depth. Loosen the Seat Adjust Lock Ring and back the Seat Adjust Screw out several turns to assure that the bullet won't be seated too deep.
- 7.** Lower the press ram and set the bullet on the case. Raise the press ram, guiding the bullet/case into the Crimp/Seater Die.
- 8.** While press ram is at the top of the stroke, thread the Seat Adjust Screw into die until resistance is felt. This resistance is the bullet starting to seat into the case.
- 9.** Set the bullet seat depth by lowering the press ram, threading the Seat Adjust Screw into the die and raising the press ram again until the desired seating depth/cartridge length is obtained. Note: Do not, at this time, tighten the Seat Adjust Lock Ring.
- 10.** Now we will set the crimp on the cartridge. Your new Hornady® Crimp/Seater die will achieve this by adjusting the Crimp Adjust Screw as opposed to loosening the Sure-Loc Lock Ring and adjusting the entire body as with most seater dies. Since the lock ring was set in step 4, it doesn't have to be moved.
- 11.** With the cartridge in the shell holder, raise the press ram again to the top of its stroke.
- 12.** Loosen the Crimp Adjust Lock Ring several turns while holding the Crimp Adjust Screw.
- 13.** Hold the Seat Adjust Screw from turning and thread the Crimp Adjust Screw into the die until resistance is felt. This resistance is, again, the case starting to crimp.
- 14.** Continue setting crimp by lowering press ram, holding the Seat Adjust Screw, threading the Crimp Adjust Screw into the die in 1/8 turn increments, and raising the press ram again until the proper crimp is obtained. The 1/8 turn recommendation is due to the fine adjustment of the crimp. In the next step, a bullet will be seated and crimped in one step and due to this, an incorrect crimp or over excessive crimp will result in bullet swaging or case bulging.
- 15.** Next, lower the press ram and remove the cartridge. Place the next set of components in the press and raise the ram to the top of the stroke, guiding the case/bullet into the die. This will seat the bullet as well as crimp it in the case.
- 16.** Fine tune the crimp/seat depth if necessary. Remember when adjusting the Crimp Adjust Screw, hold the Seat Adjust Screw and when adjusting the Seat Adjust Screw, hold the Crimp Adjust Screw. Doing this will allow the crimp amount to be adjusted without moving the seating depth and vice versa.
- 17.** Once the crimp amount and the seat depth have been obtained, the Crimp Adjust Lock Ring and Seat Adjust lock ring will need to be tightened. First, tighten the Crimp Adjust Lock Ring; you'll need to hold the Crimp Adjust Screw so it doesn't move. Then tighten the Seat Adjust Lock Ring down firmly on the Rubber Flat Washer. Hold the Seat Adjust Screw so it doesn't turn.
- 18.** Your die should now be set and will give you years of reloading enjoyment.

EXPLODED VIEW

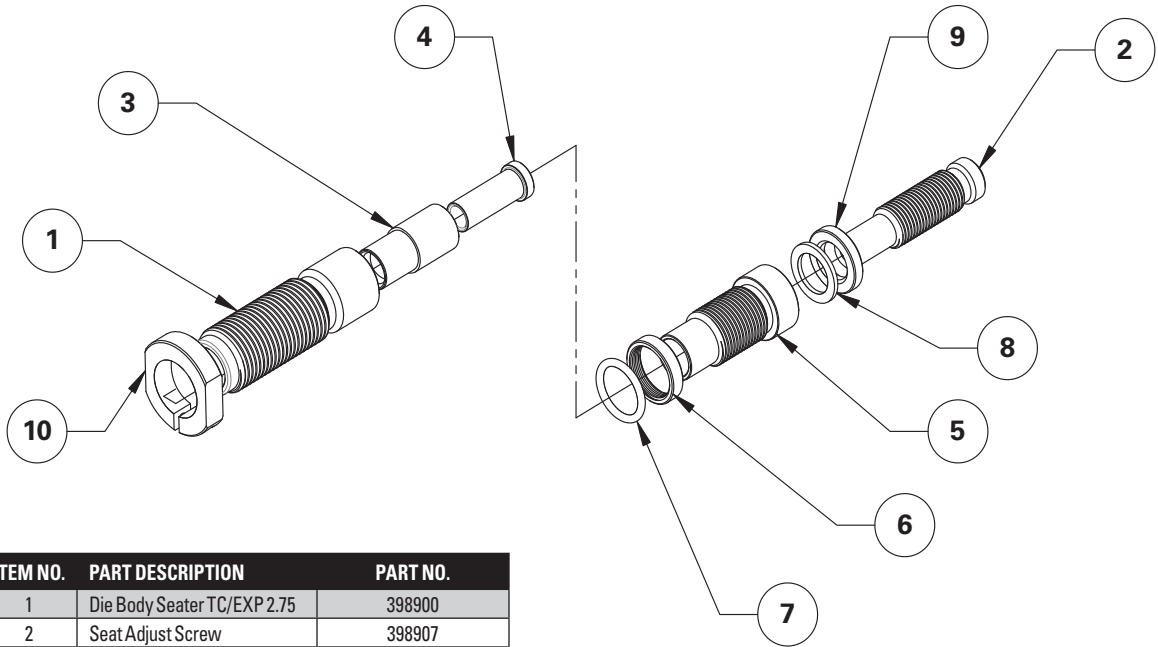

ITEM NO.	PART DESCRIPTION	PART NO.
1	Die Body Seater TC/EXP 2.75	398900
2	Seat Adjust Screw	398907
3	Alignment Sleeve	Varies with caliber
4	Seating Stem	Varies with caliber
5	Crimp Adjust Screw	398905
6	Crimp Adjust Lock Ring	398906
7	O-Ring	480083
8	Washer Flat Rubber	398067
9	Ring Lock Seater Die	044800
10	Sure-Loc Lock Ring	044000

NOTE: When calling for parts, please reference part number.



Hornady[®]
Accurate. Deadly. Dependable.

P.O. Box 1848 • Grand Island, NE 68802-1848
(308) 382-1390 • www.hornady.com